

WIRELESS TRANSMITTER-RECEIVER SYSTEMS

%RH, RTD, THERMOCOUPLE, LEVEL

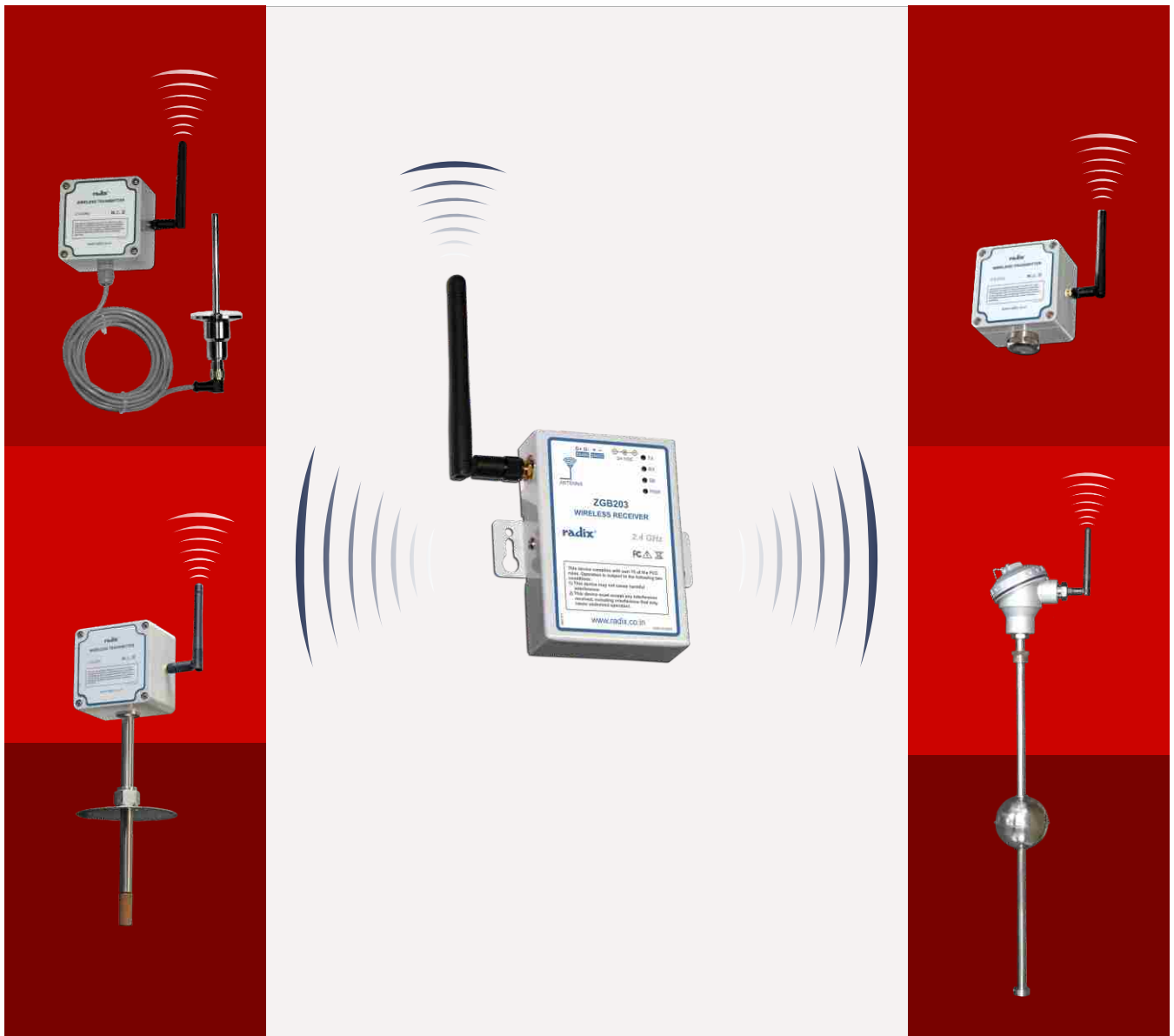

radix[®]
www.radix.co.in

WIRELESS RTD TRANSMITTERS



TYPE A



TYPE B

ABOUT ZGE201

ZGE201 is a wireless transmitter used to measure the temperature of an RTD sensor and transmit it to a wireless receiver ZGB203 connected to a PC for data logging. It is available in surface mount as well as a variety of other RTD sensor designs. The RTD can be integral with the transmitter, or remote, connected by a cable.

FEATURES

- 2 years+ battery life
- Pt100 input
- Operates in the free radio band 2.4GHz
- Transmits temperature value, transmitter internal temperature, wireless signal strength & battery condition
- User programmable transmit interval
- IP54 protection
- RTD sensor design to customer's specifications
- Works with 3 x AA Duracell batteries

WIRELESS RTD TRANSMITTERS

SPECIFICATIONS

All specifications at ambient of 25 °C, unless specified otherwise

INPUT

Type A (Surface mount with integral RTD sensor)

Input type	Pt100
Range	0 °C ~ 50 °C
Accuracy	±0.5 °C

Type B (Surface mount with remote RTD sensor)

Input type	Pt100
Range	-200 °C ~ 850 °C *
Accuracy	±0.5 °C for 0~400 °C *
Sensor design	User specified *

(Note : Remote Sensor connected to the transmitter unit as shown in the image is for illustrative purpose. No remote sensor will be provided with the transmitter unit. If required it has to be ordered separately by providing detailed specifications for the sensor)

* RTD sensor design can be modified to customer's specifications.
* Instrument temperature must not exceed 50 °C on a continuous basis, and 60 °C for a short duration. Increase in instrument temperature may cause damage.

PROGRAMMABLE PARAMETERS#

Device ID	1 ~ 25
Transmit interval	5 ~ 3600 seconds
Computer interface	USB to RS232 converter (Radix Model : DCC501) is required to configure programmable parameters #

Note 1: Software utility ZGU202 is supplied with ZGE201 for configuring programmable parameters.

Note 2: DCC501 will not be provided with the transmitter unit. It has to be ordered separately.

DATA TRANSMITTED TO HOST

Temperature value, transmitter internal temperature, wireless signal strength and battery condition

POWER

Battery	3 X AA type Duracell batteries
Battery life	2 years (at 1 minute transmit interval)

(Note : Battery life is specified at an ambient temperature of 25 °C. For ambient temperatures below this, the battery life reduces with temperature. The lower the temperature, the larger will be the reduction in the battery life.)

RF (WIRELESS) COMMUNICATION

RF frequency transceiver carrier	ISM 2.4GHz, direct sequence spread spectrum
RF output power	18dBm (63mW)
Range of RF communication	Up to 1 km outdoor line of sight Up to 40 m indoor / urban
RF data packet standard	IEEE 802.15.4, open communication architecture

MECHANICAL

Type A (Surface mount with integral RTD sensor)

Enclosure	ABS plastic
Dimensions (in mm)	80(L) x 82(W) x 55(H) (without antenna) See Fig 2
Protection	IP54 (The integral sensor does not come with IP54)
Mounting	Surface
Sensor location	Integral

Type B (Surface mount with remote RTD sensor)

Enclosure	ABS plastic
Dimensions (in mm)	80(L) x 82(W) x 55(H) (without antenna) See Fig 3
Protection	IP54
Mounting	Surface
Sensor location	Remote (connected by cable)
Cable entry for RTD cable	PG7, suitable for cable dia 3 to 6.5 mm

ENVIRONMENTAL CONDITIONS (ELECTRONICS)

Operating ambient temperature	0 °C to 50 °C
Relative humidity	0~95%, non-condensing

ORDERING INFORMATION

Type A : Wireless RTD Transmitter

Surface mount with integral RTD sensor

Order Code	2707
------------	------

Type B : Wireless RTD Transmitter

Surface mount with remote RTD sensor

Order Code	2708
------------	------

Note 1 : The RTD will be designed to customer specifications if ordered.

Note 2 : Remote Sensor connected to the transmitter unit as shown in the image is for illustrative purpose. No remote sensor will be provided with the transmitter unit. If required it has to be ordered separately by providing detailed specifications for the sensor.

Note 3 : While using remote sensor care should be taken to maintain instrument temperature below 50°C. Increase in temperature may cause damage.

Note 4 : Customer may order this without external RTD. He can connect his existing RTD.

WIRELESS

THERMOCOUPLE TRANSMITTERS



ABOUT ZGE202

ZGE202 is a wireless transmitter used to measure the temperature of a thermocouple and transmit it to a wireless receiver ZGB203 connected to a PC for data logging. Surface mount with remote sensor design is available for wireless thermocouple transmitter.

FEATURES

- 2 years+ battery life
- User configurable for thermocouple input type J, K, T, E, R, S, B, N
- Operates in the free radio band 2.4GHz
- Transmits temperature value, transmitter internal temperature, wireless signal strength & battery condition
- User programmable transmit interval
- IP54 protection
- Works with 3 x AA Duracell batteries

TABLE1

SENSOR / INPUT	RANGE LIMITS (°C / EU)		RANGE IN WHICH ACCURACY IS SPECIFIED		TYPICAL ACCURACY AT 30 °C (°C / EU)	WORST CASE ACCURACY (°C / EU)
	LOW SCALE	HIGH SCALE	LOW SCALE	HIGH SCALE		
Pt - 6% Rh / Pt - 30% Rh (B)	400	1800	400	1800	± 3	± 5
Chromel / Constantan (E)	-200	850	0	850	± 1	± 3
Iron / Constantan (J)	-200	760	0	760	± 1	± 3
Chromel / Alumel (K)	-200	1370	-50	1200	± 1	± 3
Nicrosil / Nisil (N)	-200	1300	-50	1200	± 1	± 3
Pt / Pt - 13% Rh (R)	0	1700	400	1700	± 2	± 5
Pt / Pt - 10% Rh (S)	0	1700	400	1700	± 2	± 5
Copper / Constantan (T)	-200	400	-200	400	± 1	± 3

WIRELESS

THERMOCOUPLE TRANSMITTERS

SPECIFICATIONS

All specifications at ambient of 25 °C, unless specified otherwise

INPUT

Input type	Thermocouple : J, K, T, E, R, S, B, N
Range	Refer table 1
Accuracy	Refer table 1
Sensor design	User specified*

(Note : Remote Sensor connected to the transmitter unit as shown in the image is for illustrative purpose. No remote sensor will be provided with the transmitter unit. If required it has to be ordered separately by providing detailed specifications for the sensor)

* Thermocouple sensor design can be modified to customer's specifications.

* Instrument temperature must not exceed 50 °C on a continuous basis, and 60 °C for a short duration. Increase in instrument temperature may cause damage.

PROGRAMMABLE PARAMETERS[#]

Device ID	1 ~ 25
Transmit interval	5 ~ 3600 seconds
Computer interface	USB to RS232 converter (Radix Model : DCC501) is required to configure programmable parameters #

Note 1: Software utility ZGU202 is supplied with ZGE202 for configuring programmable parameters.

Note 2: DCC501 will not be provided with the transmitter unit. It has to be ordered separately.

DATA TRANSMITTED TO HOST

Temperature value, transmitter internal temperature, wireless signal strength and battery condition

POWER

Battery	3 X AA type Duracell batteries
Battery life	2 years (at 1 minute transmit interval)

(Note : Battery life is specified at an ambient temperature of 25 °C. For ambient temperatures below this, the battery life reduces with temperature. The lower temperature, the larger will be the reduction in the battery life.)

RF (WIRELESS) COMMUNICATION

RF frequency transceiver carrier	ISM 2.4GHz, direct sequence spread spectrum
RF output power	18dBm (63mW)
Range of RF communication	Up to 1 km outdoor line of sight Up to 40 m indoor / urban
RF data packet standard	IEEE 802.15.4, open communication architecture

MECHANICAL

Surface mount with remote sensor

Enclosure	ABS plastic
Dimensions (in mm)	80(L) x 82(W) x 55(H) (without antenna) See Fig 3
Protection	IP54
Mounting	Surface
Sensor location	Remote (connected by cable)
Cable entry	PG7, Suitable for cable dia 3 to 6.5 mm

ENVIRONMENTAL CONDITIONS (ELECTRONICS)

Operating ambient temperature	0 °C to 50 °C
Relative humidity	0~95%, non-condensing

ORDERING INFORMATION

Wireless Thermocouple Transmitter

Surface mount with remote sensor

Order Code	2709
------------	------

Note 1 : The thermocouple sensor will be designed to customer specifications if ordered.

Note 2 : Remote sensor connected to the transmitter unit as shown in the image is for illustrative purpose. No remote sensor will be provided with the transmitter unit. If required it has to be ordered separately by providing detailed specifications for the sensor.

Note 3 : While using remote sensor care should be taken to maintain instrument temperature below 50°C. Increase in temperature may cause damage.

Note 4 : Customer may order this without external thermocouple sensor. He can connect his existing thermocouple sensor.

WIRELESS

RELATIVE HUMIDITY & TEMPERATURE TRANSMITTERS



TYPE B



TYPE A



TYPE C

ABOUT ZGE203

ZGE203 is a wireless transmitter used to measure the Relative Humidity and Temperature of air and transmit it to a wireless receiver ZGB203 connected to a PC for data logging. It is available in surface mount, duct-mount and remote sensor versions.

FEATURES

- 2 years+ battery life
- Integral or remote RH+T sensor
- Operates in the free radio band 2.4GHz
- Transmits relative humidity, temperature, transmitter internal temperature, wireless signal strength & battery condition
- User programmable transmit interval
- IP54 protection
- Works with 3 x AA Duracell batteries

WIRELESS

RELATIVE HUMIDITY & TEMPERATURE TRANSMITTERS

SPECIFICATIONS

All specifications at ambient of 25 °C, unless specified otherwise

INPUT

Sensor / Input	
1) RH + T	Digital sensor
2) RH	Digital sensor
Temperature	RTD sensor - Pt100
Range	Refer TABLE 1*
Accuracy	Refer TABLE 1*

* Instrument temperature must not exceed 50 °C on a continuous basis, and 60 °C for a short duration. Increase in instrument temperature may cause damage.

PROGRAMMABLE PARAMETERS[#]

Device ID	1 ~ 25
Transmit interval	5 ~ 3600 seconds
Computer interface	USB to RS232 converter (Radix Model : DCC501) is required to configure programmable parameters #

Note 1: Software utility ZGU202 is supplied with ZGE203 for configuring programmable parameters.

Note 2: DCC501 will not be provided with the transmitter unit. It has to be ordered separately.

POWER

Battery	3 X AA type Duracell batteries
Battery life	2 years (at 1 minute transmit interval) (Note : Battery life is specified at an ambient temperature of 25 °C. For ambient temperatures below this, the battery life reduces with temperature. The lower temperature, the larger will be the reduction in the battery life.)

DATA TRANSMITTED TO HOST	Relative humidity, temperature, transmitter internal temperature, wireless signal strength & battery condition
---------------------------------	--

RF (WIRELESS) COMMUNICATION

RF frequency transceiver carrier	ISM 2.4GHz, direct sequence spread spectrum
RF output power	18dBm (63mW)
Range of RF communication	Up to 1 km outdoor line of sight Up to 40 m indoor / urban
RF data packet standard	IEEE 802.15.4, open communication architecture

MECHANICAL

Type A (Surface mount)

Enclosure	ABS plastic
Dimensions (in mm)	80(L) x 82(W) x 55(H) (without antenna) See Fig 2
Protection	IP54
Mounting	Surface
Sensor location	Integral

Type B (Duct mount)

Enclosure	ABS plastic
Dimensions (in mm)	See Fig 4
Protection	IP54 (The integral sensor does not come with IP54)
Mounting	Duct
Sensor location	Integral
Sensor tube	SS304
Filter	Sintered bronze
Process connection	Adjustable flange

Type C (Surface mount with remote sensor)

Enclosure	ABS plastic
Dimensions (in mm)	80(L) x 82(W) x 55(H) (without antenna) See Fig 3
Protection	IP54
Mounting	Surface
Sensor location	Remote (connected by cable)
Sensor cable length	a) 10 meter b) 20 meter
Cable entry	PG7, suitable for cable dia 3 to 6.5 mm

ENVIRONMENTAL CONDITIONS (ELECTRONICS)

Operating ambient temperature	0 °C to 50°C
Relative humidity	0~95%, non-condensing

WIRELESS

RELATIVE HUMIDITY & TEMPERATURE TRANSMITTERS

TABLE 1

Sensor type	RH + T : Digital sensor		RH : Digital sensor Temperature : RTD sensor - Pt100	
	RH	Temperature	RH	Temperature
Range limits	10 to 90%	0 to 50 °C	10 to 90%	-20 to 70 °C
Accuracy	±2% for 20 to 80% RH (refer Fig 1)	±0.5 °C for 0 to 60 °C	±2% for 20 to 80% RH (refer Fig 1)	±0.5 °C for -20 to 70 °C

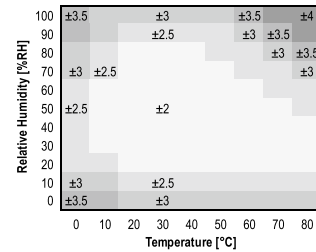

Fig 1

Typical accuracy of relative humidity measurements given in %RH for temperatures 0–80 °C

ORDERING INFORMATION

Type A : Wireless Relative Humidity & Temperature Transmitters

Surface mount

Order Code	A	Temperature measurement type
2710	1	RH + T : Digital sensor
	2	RH : Digital sensor Temp : RTD sensor - Pt100

Type B : Wireless Relative Humidity & Temperature Transmitters

Duct mount

Order Code	A	Temperature measurement type	B	Sensor Length
2711	1	RH + T : Digital sensor	1	200 mm
	2	RH : Digital sensor Temp : RTD sensor - Pt100	2	300 mm

Type C : Wireless Relative Humidity & Temperature Transmitters

Surface mount with remote sensor

Order Code	A	Temperature measurement type	B	Cable Length
2712	1	RH + T : Digital sensor	1	10 Meter
	2	RH : Digital sensor Temp : RTD sensor - Pt100	2	20 Meter

Ordering Options

The following ordering options are available on request.
Minimum order quantity and/or minimum order value may apply.

	Option details
1.	Customer specified RH and T ranges
2.	SS wiremesh filter

WIRELESS

LEVEL TRANSMITTER - FLOAT TYPE

ABOUT ZGE205

ZGE205 is a wireless transmitter used to measure the level of liquid and transmit it to a wireless receiver ZGB203 connected to a PC for data logging. The level sensor design can be made to customer's specifications.

FEATURES

- 1 year+ battery life
- Operates in the free radio band 2.4GHz
- Transmits tank height, height in %, signal strength & battery status
- User programmable transmit interval
- IP54 protection

APPLICATION

- Chemicals, petrochemicals, refineries
- Pharmaceutical industry
- Pressure vessels, storage tanks
- Marine industry
- Water & waste water treatment plants

CONSTRUCTION & OPERATING PRINCIPLE

- It consists of a guide tube, float & housing with the electronic transmitter circuitry.
- The level signal is measured by the sensor. The wireless transmitter transmits level, % level, transmitter internal temperature, wireless signal strength and battery condition to a receiver ZGB203 after the predefined transmission interval for data logging.



WIRELESS

LEVEL TRANSMITTER - FLOAT TYPE

SPECIFICATIONS

All specifications at ambient of 25 °C, unless specified otherwise

INPUT

Input type	Float guided level sensor
Resolution	Standard ± 12 mm
Accuracy/Repeatability	± 12 mm

PROGRAMMABLE PARAMETERS#

Device ID	1 ~ 25
Transmit interval	5 ~ 3600 seconds
Computer interface	USB connector for programming of parameters #

Software utility ZGU202 is supplied with ZGE201 for configuring programmable parameters.

POWER

Battery	AEA-798
Battery life	1 year (at 1 minute transmit interval)

(Note : Battery life is specified at an ambient temperature of 25 °C. For ambient temperatures below this, the battery life reduces with temperature. The lower temperature, the larger will be the reduction in the battery life.)

RF (WIRELESS) COMMUNICATION

RF frequency transceiver carrier	ISM 2.4GHz, direct sequence spread spectrum
RF output power	18dBm (63mW)
Range of RF communication	Up to 1 km outdoor line of sight Up to 40 m indoor / urban
RF data packet standard	IEEE 802.15.4, open communication architecture

DATA TRANSMITTED TO HOST

Level in mm, level in %, transmitter internal temperature, wireless signal strength and battery condition

MECHANICAL

Head MOC	a) Cast aluminium b) Polypropylene
Head dimensions (in mm)	See Fig 6
Protection	IP54
Process connection	a) Threaded b) Flanged : 2½" / 3 / 4" NB flanged to BS c) Triclover (sanitary applications) d) Other : ANSI or DIN standard
Mounting	Top
Measuring range	Guide tube length (GTL) - [Top dead band (D ₇) + Bottom dead band (D ₈)] Min 270mm (GTL 400mm) Max 3870mm (GTL 4000mm)
Span	One
No. of floats	One
Float size	Ø60 x 100, Ø75 x 100
Maximum pressure	3 Kg/cm ² (PP), 10Kg/cm ² (metallic MOC)
Installation	Installed internally or externally through external chamber. Still well is used in internal mounting in case of turbulence in liquid, if external mounting is not feasible or mechanical stirrer is operated in tank.

ENVIRONMENTAL CONDITIONS (ELECTRONICS)

Operating ambient temperature	0 °C to 50 °C
Relative humidity	0~95%, non-condensing

* Instrument temperature must not exceed 50 °C on a continuous basis, and 60 °C for a short duration. Increase in instrument temperature may cause damage.

ORDERING INFORMATION

Wireless Level Transmitter - Float Type

Model : ZGE205

Order Code	A	Sensor Length (L) for Head mount
2636	1	500mm
	2	1000mm

Note1 : The order codes given above are for standard level sensor designs only.

Note2 : The level sensor can be designed to the customer's specifications.

APPLICATION



WIRELESS RECEIVER

WITH RS485/MODBUS RTU

ABOUT ZGB203

The ZGB203 wireless receiver with RS485/MODBUS RTU receives the transmitted signals from ZGE201, ZGE202, ZGE203, ZGE204 transmitters & ZGB202 router. The ZGB203 acts as a MODBUS slave. This allows the data received to be accessed by any MODBUS master, eg a SCADA software on a PC, or a PLC.

FEATURES

- With RS485/MODBUS RTU
- Receives signals from ZGE201, ZGE202, ZGE203, ZGE204 transmitter & ZGB202 repeater
- Upto 25 channel data can be received
- Adjustable baudrate for RS485/MODBUS RTU
- IP20 protection

ORDERING INFORMATION

Wireless Receiver with RS485/MODBUS RTU
Model : ZGB203

Order Code	A	Antenna Type
2596	1	Surface Antenna
	2	Magnetic Antenna



SPECIFICATIONS

All specifications at ambient of 25 °C, unless specified otherwise

POWER

Adapter specification	Model : ACA203 Input : 230VAC, 50/60Hz Output : 24VDC, 1A Min (ACA203 included)
Instrument supply voltage	24VDC, 1A Min

RS485/MODBUS RTU

Baud rate (bps)	9600, 19200, 38400, 57600, 115200
Stop bit	1, 2
Parity	None, Odd, Even

RF (WIRELESS) COMMUNICATION

Maximum number of transmitters per receiver	25 (20 directly, 5 through repeater) (one receiver directly supports 20 transmitters. For every additional 20 (or less) transmitters, one repeater has to be added to the network.)
RF frequency transceiver carrier	ISM 2.4GHz, direct sequence spread spectrum
RF output power	18dBm (63mW)
Range of RF communication	Up to 1 km outdoor line of sight Up to 40 m indoor / urban
RF data packet standard	IEEE 802.15.4, open communication architecture

MECHANICAL

Enclosure	Metal
Dimensions (in mm)	90(L) x 90(W) x 20(H) (without antenna) See Fig 5
Mounting	Surface
Protection	IP20

ENVIRONMENTAL CONDITIONS (ELECTRONICS)

Operating ambient temperature	0 °C to 50 °C
Relative humidity	0~95%, non-condensing

WIRELESS RECEIVER

WITH RS485/MODBUS RTU

APPLICATION

SERIAL TO
ETHERNET
CONVERTER
WITH PoE



HOST PC RUNNING SCADA

RS485

ZONE 1

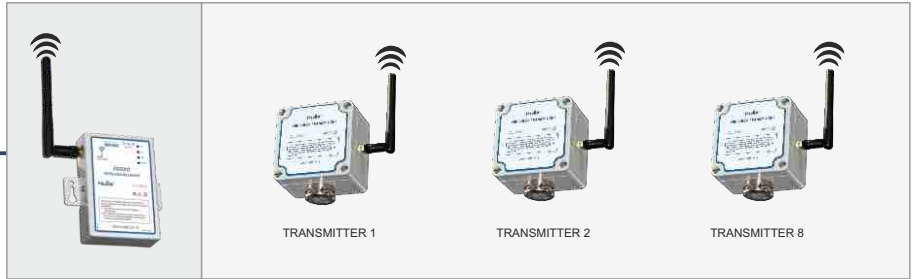

ZONE 2

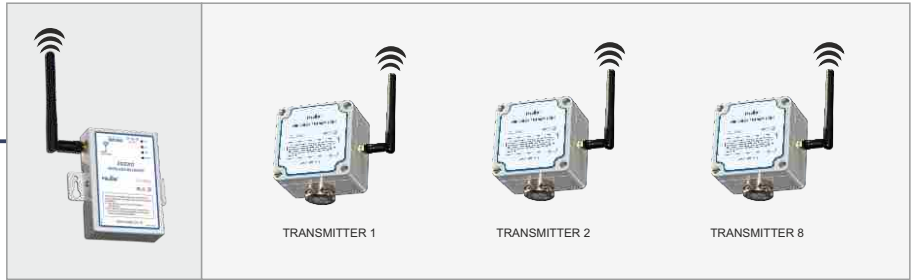

ZONE 3

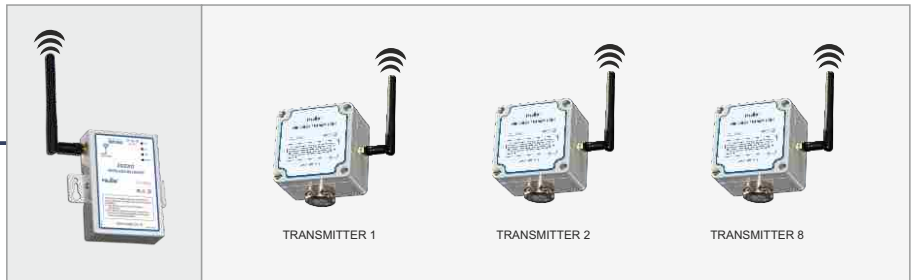

WIRELESS REPEATER

ABOUT ZGB202

Repeater ZGB202 is used to boost the wireless signal if the signal is not strong enough to travel directly from the transmitter to the receiver.

FEATURES

- Amplifies weak signal & retransmits to receiver
- Receive data from up to 20 wireless transmitters or repeater and retransmits data to receiver
- Compatible with all Radix ZGE series wireless transmitters
- Increases range up to 1km (Line of sight)
- Repeater to repeater arrangement can further increase range
- IP20 protection

ORDERING INFORMATION

Wireless Repeater

Model : ZGB202 (5V ADAPTOR)

Order Code	2552
------------	------

Wireless Repeater

Model : ZGB202 (24V ADAPTOR)

Order Code	2713
------------	------



SPECIFICATIONS

All specifications at ambient of 25 °C, unless specified otherwise

POWER

Order Code : 2552

Adapter specification

Model : ACA204
Input : 230VAC, 50/60Hz
Output : 5VDC, 1A Min
(ACA204 included)
5VDC, 1A Min

Instrument supply voltage

Order Code : 2713

Adapter specification

Model : ACA203
Input : 230VAC, 50/60Hz
Output : 24VDC, 1A Min
(ACA203 included)
24VDC, 1A Min

Instrument supply voltage

RF (WIRELESS) COMMUNICATION

Maximum number of transmitters per repeater 20

RF frequency transceiver carrier ISM 2.4GHz, direct sequence spread spectrum

RF output power 18dBm (63mW)

Range of RF communication Up to 1 km outdoor line of sight

Up to 40 m indoor / urban

RF data packet standard IEEE 802.15.4, open communication architecture

MECHANICAL

Enclosure Metal
Dimensions (in mm) 90(L) x 90(W) x 20(H)
(without antenna) See Fig 5

Mounting Surface
Protection IP20

ENVIRONMENTAL CONDITIONS (ELECTRONICS)

Operating ambient temperature 0 °C to 50 °C

Relative humidity 0~95%, non-condensing

WIRELESS TRANSMITTER-RECEIVER SYSTEMS

%RH, RTD, THERMOCOUPLE, LEVEL

ADDITIONAL ACCESSORIES

Surface Antenna: 2.4GHz 3dBi

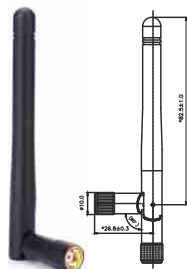

ORDER CODE : 2764*

Magnetic Antenna: 2.4 GHz 3dBi, Cable length 3 meter



ORDER CODE : 2766*

24VDC Adaptor



ORDER CODE : 2767*

USB to Mini USB Cable



ORDER CODE : 2765*

Serial to Ethernet Converter



MODEL : DCC201
ORDER CODE : 2489

Serial to Ethernet Converter with PoE



MODEL : DCC202
ORDER CODE : 2553

USB to Serial Converter - Isolated



MODEL : DCC501
ORDER CODE : 2555

* Images shown are for illustration purpose only, Colour or model may differ from the picture shown. However features will remain same.

DIMENSIONS mm

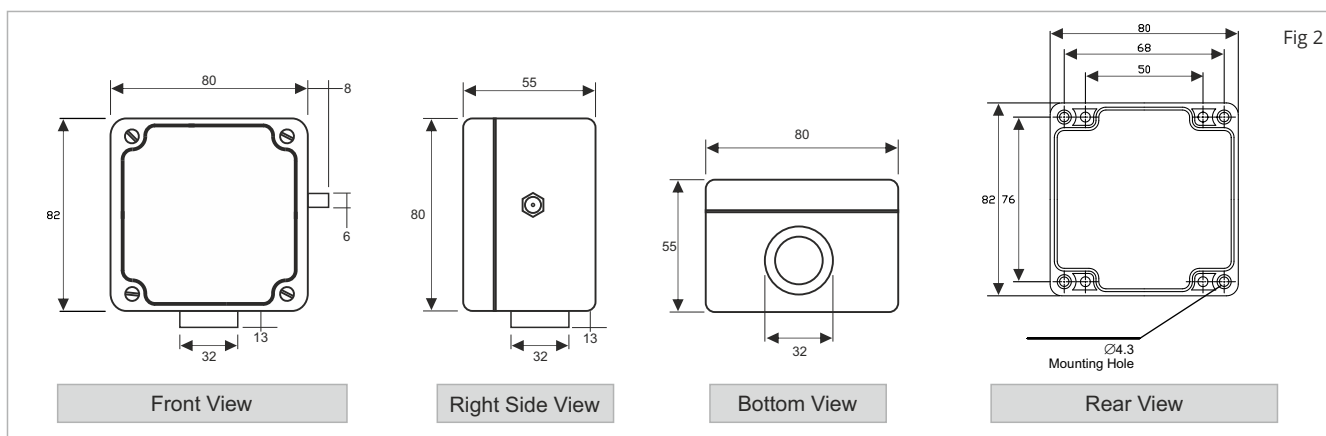

WIRELESS TRANSMITTER-RECEIVER SYSTEMS

%RH, RTD, THERMOCOUPLE, LEVEL

DIMENSIONS mm

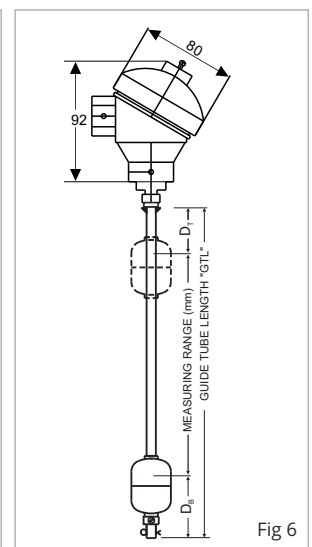
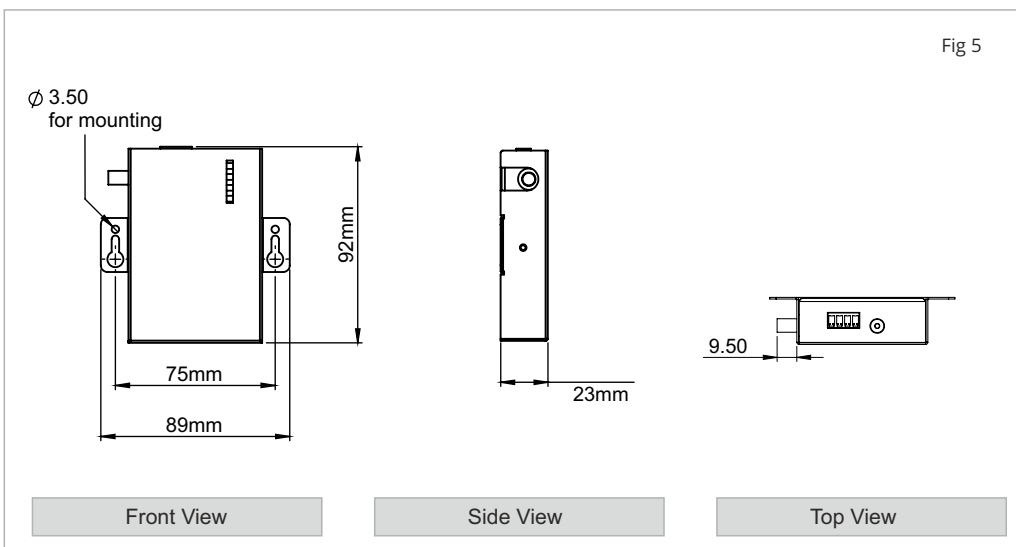
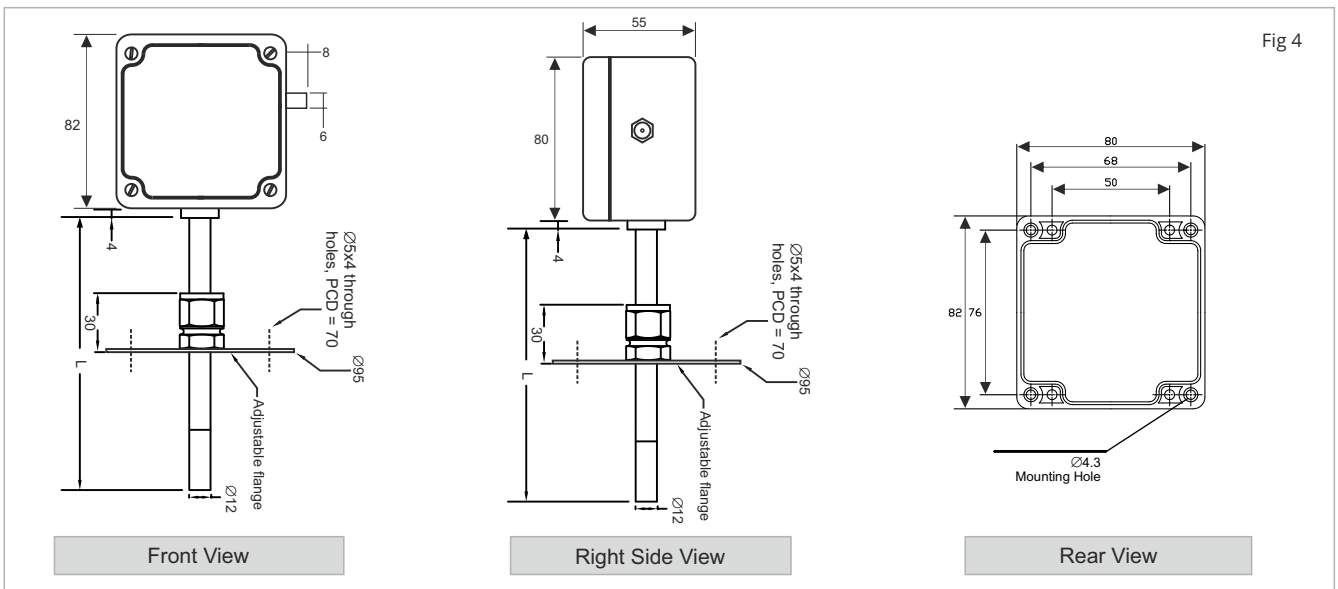
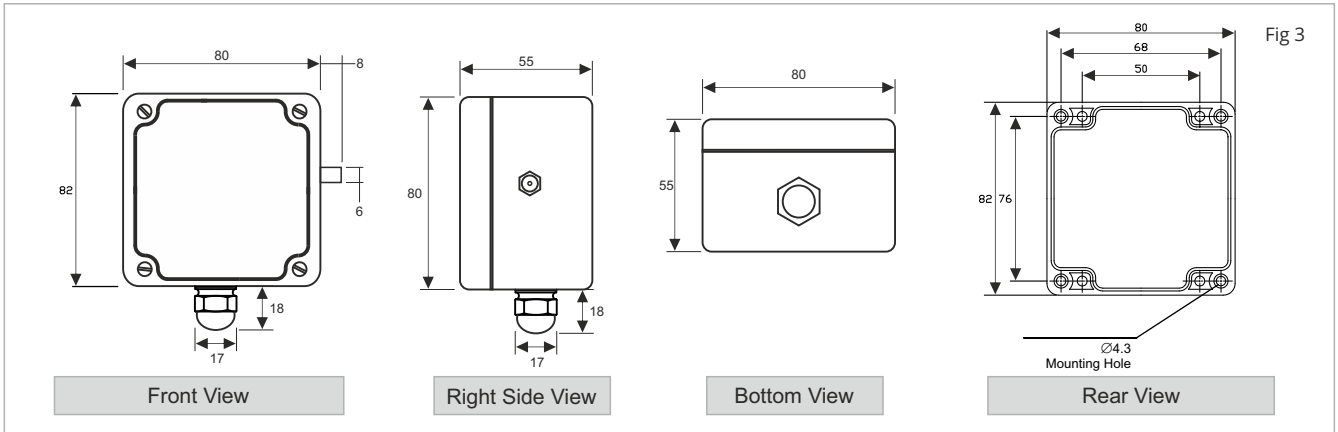

AUTOMATION PROJECTS



CONTROL PANELS



LEVEL PRODUCTS



INSTRUMENTS



RTDs & THERMOCOUPLES



PRESSURE GAUGES, DIAL THERMOMETERS



ENQUIRIES

Instruments : sales@radix.co.in
Sensors : sensors@radix.co.in
Gauges : gauges@radix.co.in
Automation : automation@radix.co.in
Level : level@radix.co.in
Dwyer : sales@radix.co.in

RADIX ELECTROSYSTEMS PVT LTD
EL-135/136/137, Electronics Zone
TTC Indl. Area, MIDC, Mahape
Navi Mumbai - 400 710, India
Tel : + 91 22 42537707
Cell : + 91 8879517740 · sales@radix.co.in